

Digital Biological Microscope

STM-2040BD

Instruction Manual

This manual is for digital biological microscope Model STM-2040BD. For the operation of software part, please see the CD. To ensure the safety, obtain optimum performance and to familiarize yourself fully with the use of this microscope, it is strongly recommended that you study this manual thoroughly before operating the microscope.

CONTENTS.....	1
USER NOTICES.....	2
1 Components Name	3
2 Assembly	4
2.1 Assembly Diagram	4
2.2 Assembly Procedures	5
3 Adjustment	9
3.1 Adjustment Set Diaphragm.....	9
3.2 Adjustment Procedures	11
4 Technical Specifications	14
5 Outfit.....	15
6 Trouble Shooting.....	16

1. Safety Note

1. Open the box carefully to avoid the accessories, like lens, dropping to ground or being damaged.
2. Do keep the instrument out of direct sunlight, high temperature or humidity, dusty and easy shaking environment. Make sure the stage is flat, horizontal and firm enough.
3. When moving the microscope, carefully carry it with the handle and the base.
4. When running, the lamp house and nearby parts will be very hot. Please ensure there is enough cooling room for them.
5. Make sure the instrument is earthed, to avoid lighting strike.
6. For safety, be sure the main switch is in "O"(off) state and cut off the power supply before replacing the bulb or the fuse. If you replace the bulb during use or right after use, allow the lamp bulb and the lamp house to cool completely before touching.
(Designated bulb: 6V/20W Halogen Lamp)
7. Check the input voltage: be sure the input voltage which is signed in the back of the microscope is consistent with the power supply voltage, or it will bring a serious damage to the instrument.

II. Maintenance and Care

1. All the lenses have been adjusted properly; do not dismount them by yourself please.
2. The nosepiece and coarse and fine focusing parts are so delicate that it is forbidden to disassemble them carelessly by yourself.
3. Keep the instrument clean, and do not pollute the optical element when wiping away the dust on the instrument.
4. The contaminations on the prism, like fingerprints and oil smudges, could be gently wiped with a piece of soft cloth or tissue paper, gauze which has been immersed in pure alcohol or ether.
(Note that the alcohol and ether are highly flammable, do keep them away from the fire or potential sources of electrical sparks, and use them in a drafty room as possible as you can.)
5. Do not attempt to use organic solvents to clean the microscope components other than the glass components. To clean them, use a lint-free, soft cloth slightly moistened with a diluted neutral detergent.
6. When using, if the microscope is splashed by liquid, cut off the power at once, and wipe away the splash.
7. Do not disassemble any parts of the microscope, as this will affect the function or reduce the performance of the microscope.
8. Place the instrument in a cool, dry position. When not using the microscope, keep it covered with a dust cover. Make sure the lamp socket is cool before covering the microscope.

1. Components Name

STM-2040BD

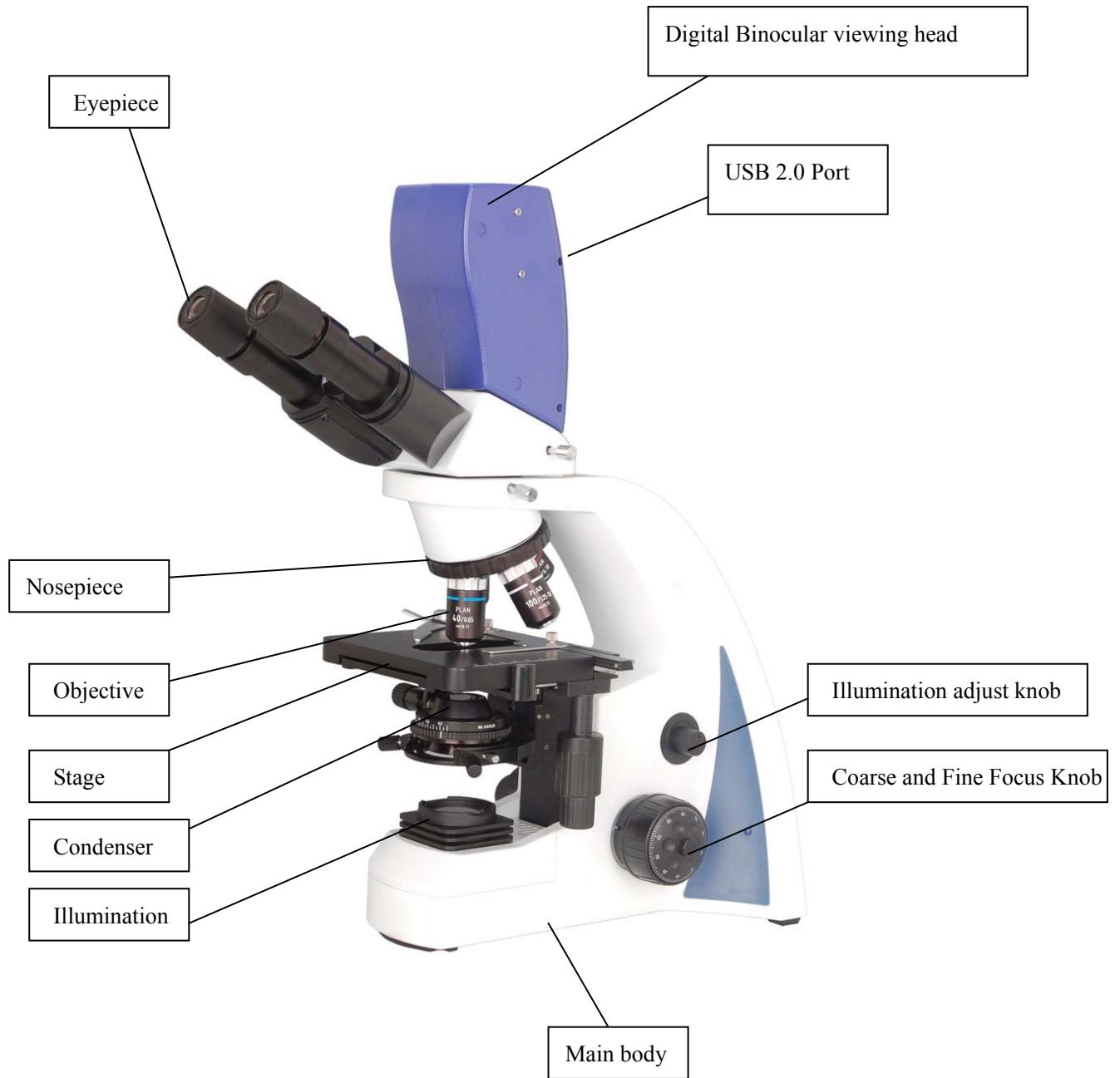

2 Assembly

2-1 Assembly Diagram

Hereby use the image of STM-2040B, except the head, other parts is the same as STM-2040BD. The following figure shows the installation sequence of the components. The number in the figure shows the assembly steps.

- ★ Before installing, be sure every components is clean, do not score any parts or glass surface.
- ★ Keep well with hexagon wrench provided. When changing the components, you will need it again.

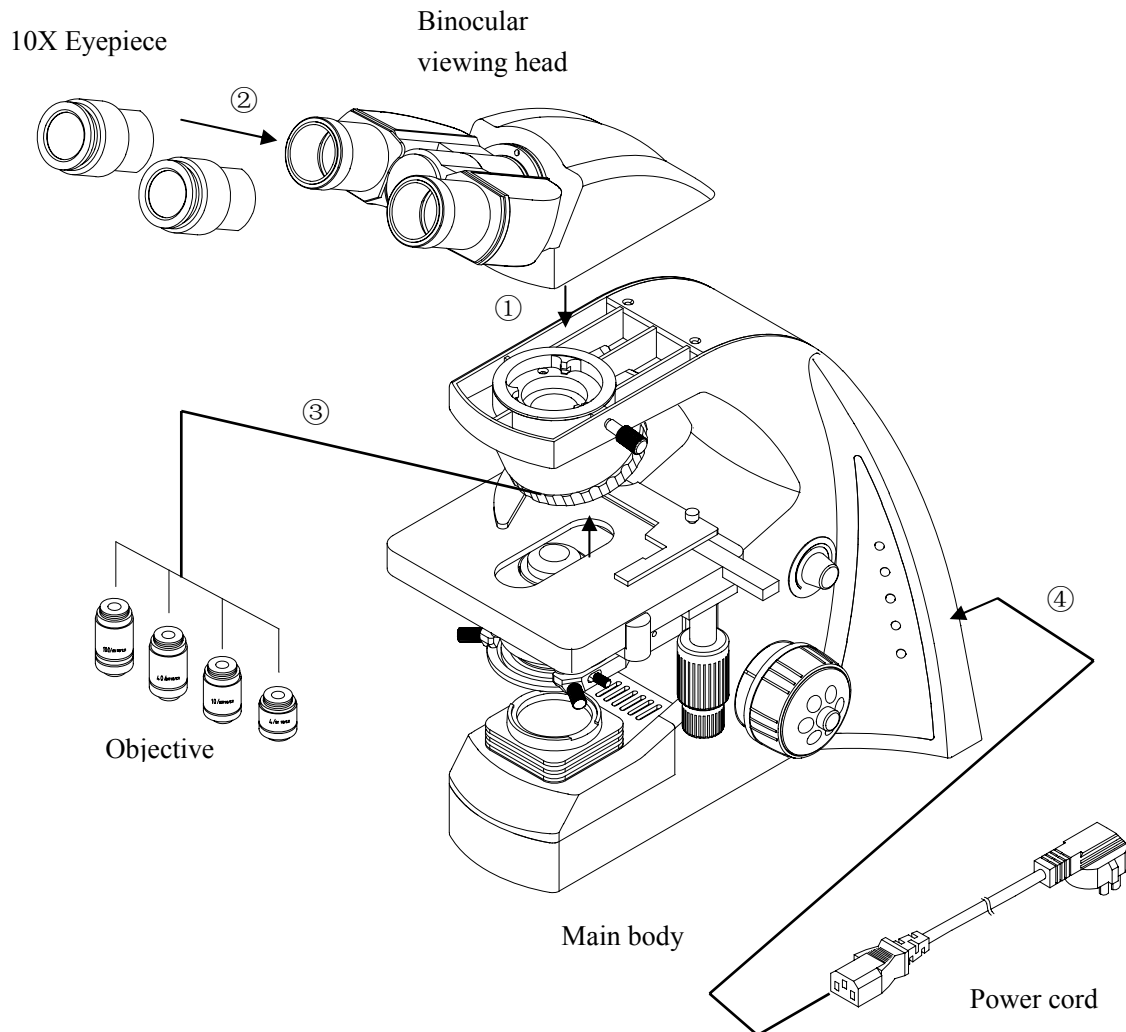

2.2 Assembly Procedure

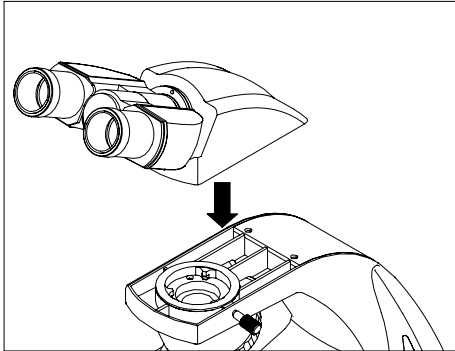

Fig.1

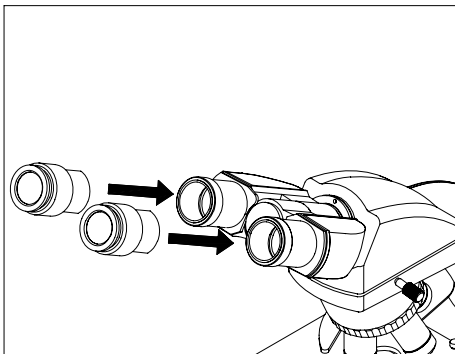

Fig.2

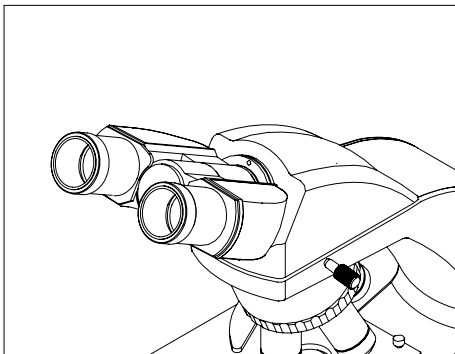

Fig.3

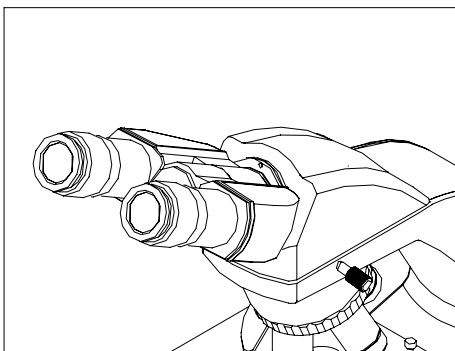

Fig.4

2.2.1 Installing binocular viewing head (Fig.1-2)

Insert the binocular viewing head into the microscope head and turn it to a proper position, then screw down the bolt to fix it.

2.2.2 Installing the eyepiece (Fig3-4)

Insert the eyepiece into the eyepiece tube until they are against each other, as shown in Fig.4.

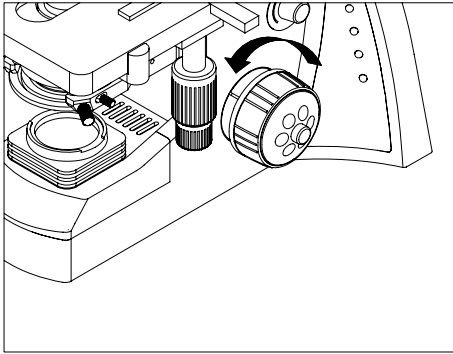

Fig.5

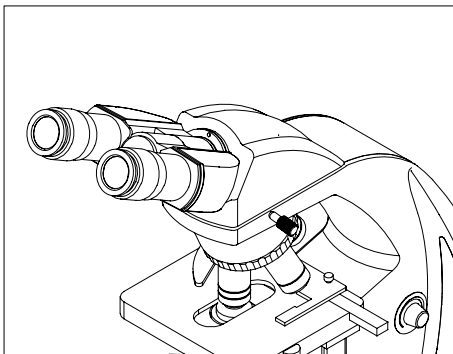

Fig.6

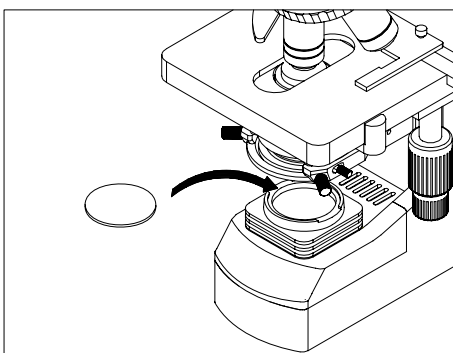

Fig.7

2.2.3 Installing the objective (Fig.5-6)

1. Adjusting the coarse focus knob until the support device of the mechanical stage reaches its low limit position.
2. Screw the lowest magnification objective into the nosepiece from the left or the right side, then revolve the nosepiece clockwise and mount other objectives by the sequence of low to high magnification

◇ Installing objective this way will make the change of magnification to be easier during using.

★ Clean the objective regularly, for lens is susceptible to dust.

★ When operating, use 10× magnification objective to search and focus specimen firstly, then replace with higher magnification objective if necessary.

★ When replacing the objective, slowly turn the nosepiece until you hear “clicked”, that means the objective is in place.

2.4 Mounting the filters (Fig.7)

1. Place the required filter in front of the condenser.

★ the filter of the standard outfit is green and baby blue.

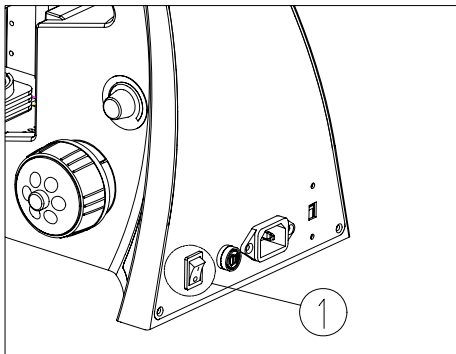

Fig.8

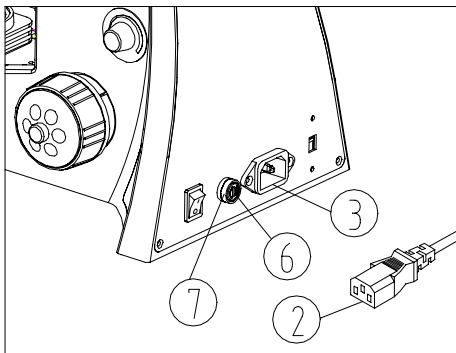

Fig.9

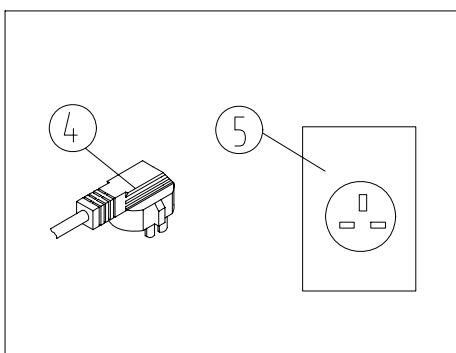

Fig.10

2.2.5 Connecting the Power Cord (Fig.8-10)

★ The cable and cords are vulnerable when bent or twisted, never subject the power cord to excessive force.

1. Set the main switch① to “O” (off) state before connecting the power cord.
2. Insert the plugs② into the power jack ③of the microscope safely.
3. Plug the power cord④ into the power supply receptacle⑤. Make sure the connection is well.

★ Do use the supplied power cord all the time. If lost or damaged, select the same standard cord, please.

★ A wide range of voltage ,like 100V~240V, is acceptable for this microscope.

2.2.6 Replacing the fuse (Fig.8-10)

Do remember to set the main switch① to the state “O” (OFF) and unplug the power cord before replacing the fuse. Rotate the fuse⑥ out of the holder⑦ with the “--”type screwdriver, replace with a new fuse, then rotate it back to the holder again.

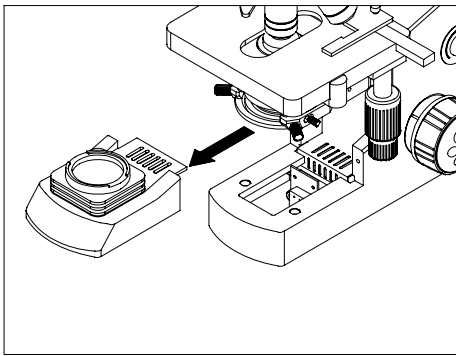

Fig.11

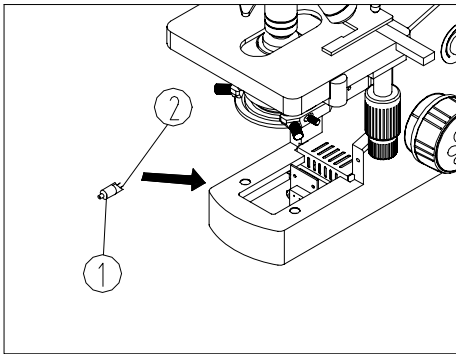

Fig.12

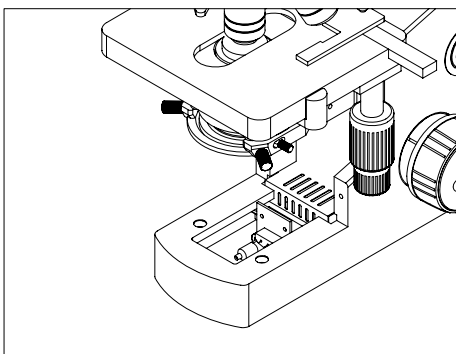

Fig.13

2.2.7 Installing and Replacing the bulb (Fig.11-13)

✧ Please use the specified halogen Lamp 6V20W.

1. Pull out the condenser holder as shown in Fig.11.
2. Hold the bulb① after you wrap it with gauze or other protection materials, and then insert its pin② deeply into the jack in the lamp holder.
3. During microscope using or soon after it is turned off, the bulb, the lamp house and nearby parts will be very hot and will cause serious burns. Please turn the main switch to “O” (off) and disconnect the power plug, and make sure the bulb, the lamp room and periphery are all cool. Then, you can do your replacing.

★ **Insert the bulb gently. Squeezing too hard will damage the bulb.**

★ **To prevent reduced bulb life or cracking, do not touch the bulb with bare hands. If fingerprints are accidentally left on the bulb, wipe the bulb with a soft cloth.**

4. Place the condenser holder back and press fit.

3. Adjustment and operation

STM-2040BD

3.1 Adjustment set diagram (Fig.14-15)

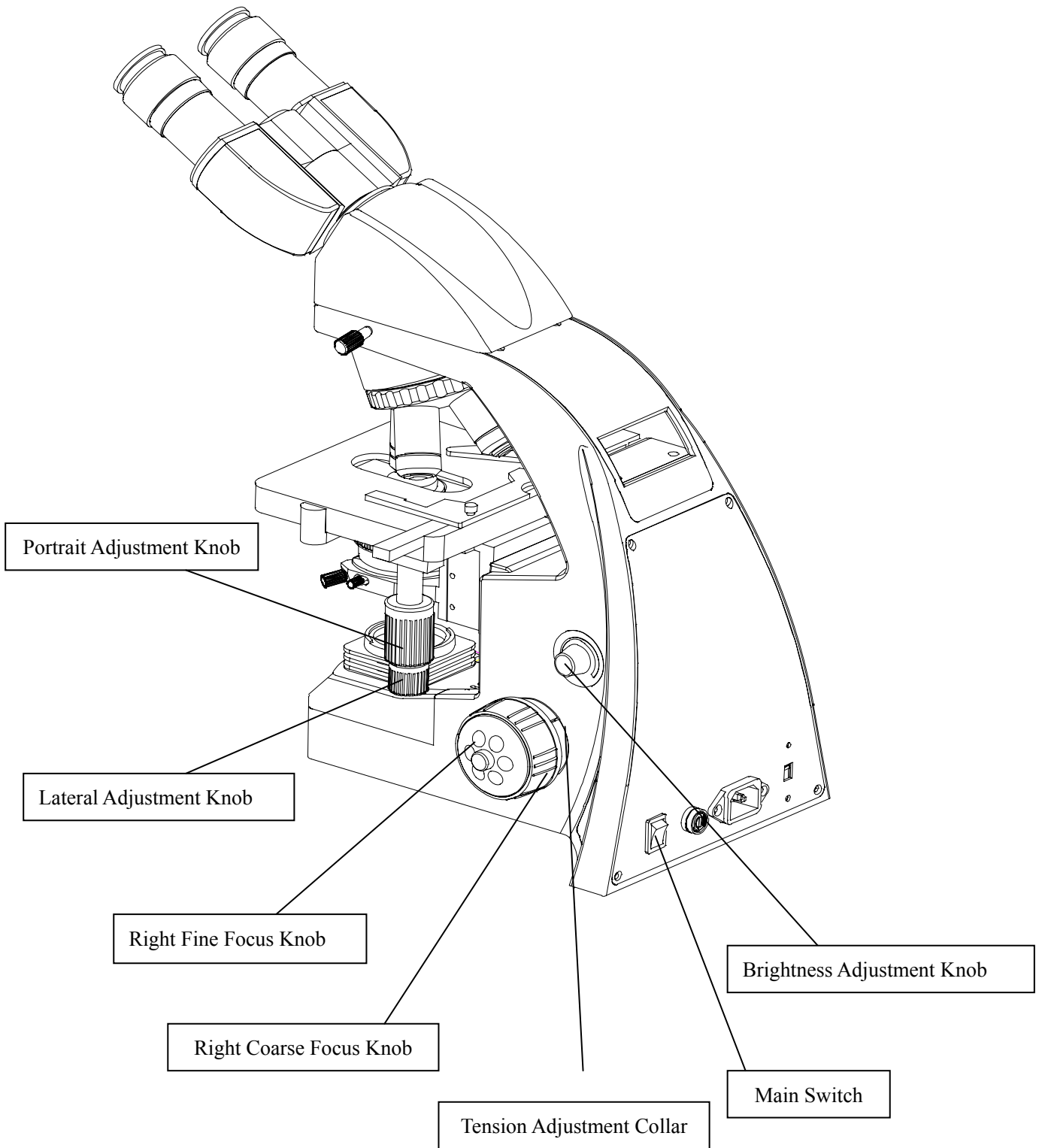

Fig.14

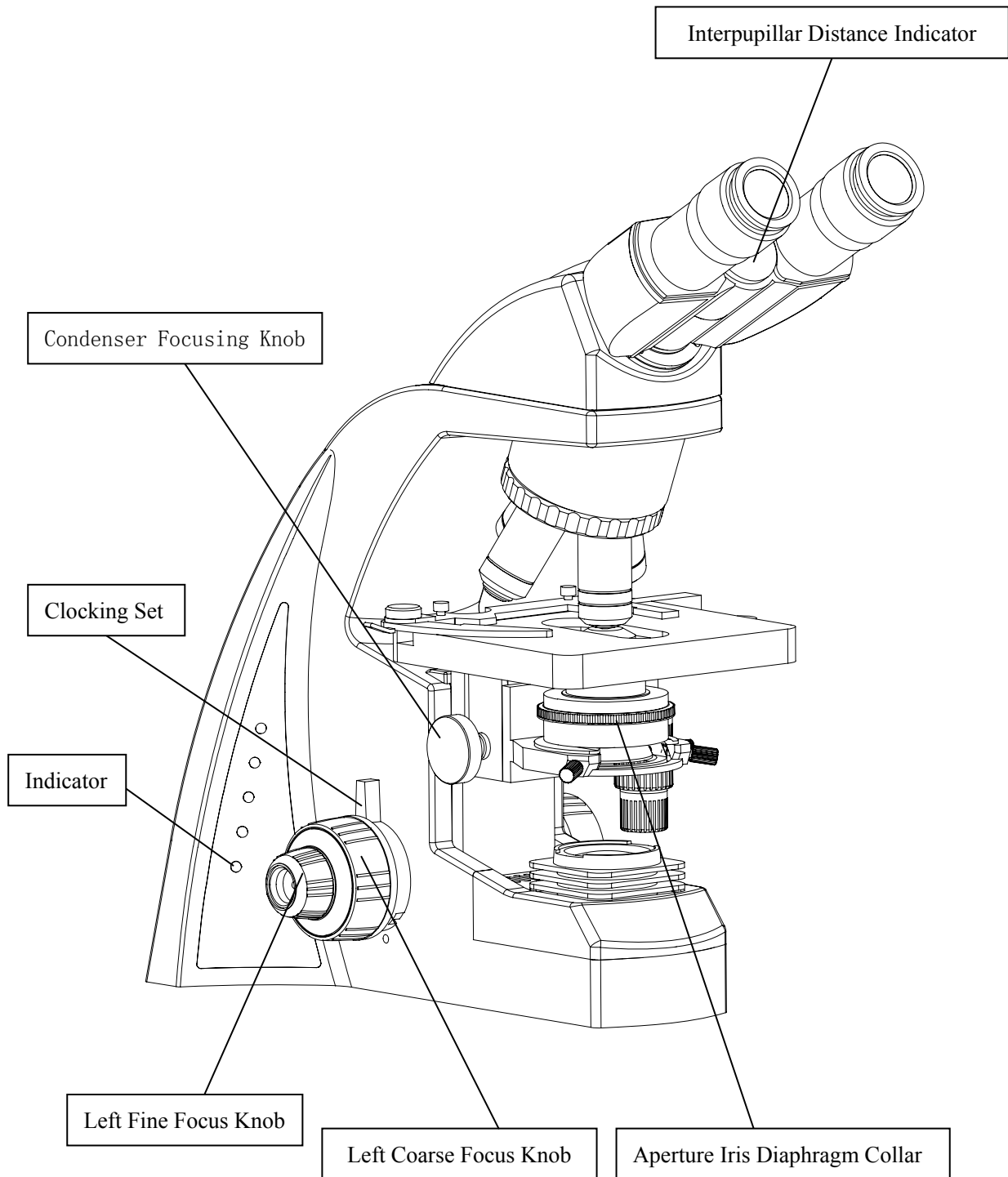

Fig.15

3.2 Adjustment and Operation

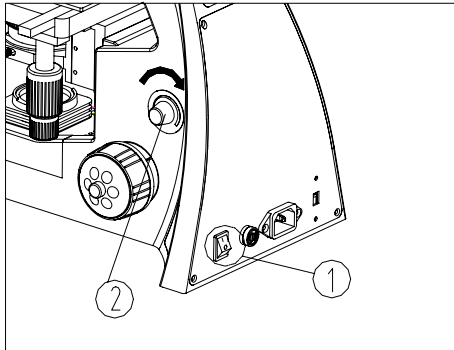

Fig.16

3.2.1 Brightness Adjustment (Fig.16)

1. Connect the power cord and set the main switch to “—”state (ON).
2. Turning the brightness adjustment knob clockwise, the voltage raise, and the brightness strengthen; whereas turning at the contra direction, the voltage decline, and the brightness weaken.

★ Using the microscope with low voltage in the voltage range can prolong the service life of the bulb.

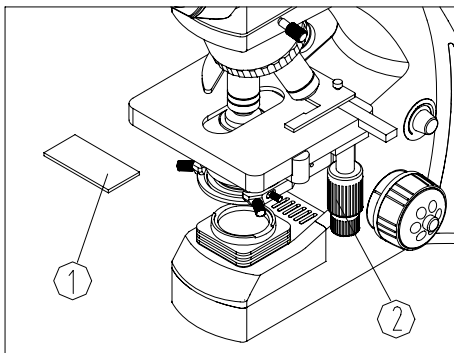

Fig.17

3.3.2 Placing the Specimen (Fig.17)

1. Place the specimen① in the center of the mechanical stage and use the stage clips to clamp it.
2. Turn the portrait and lateral adjustment knob② of the mechanical ruler, move the specimen to the required position.

★ **Be careful when changing the objective. If you finish the observation with the short working distance objective, and want to change another one, be careful of not letting the objective touch the specimen.**

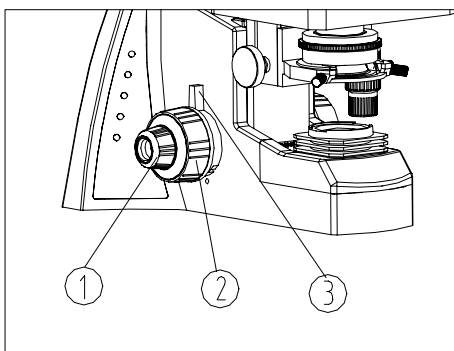

Fig.18

3.3.3 Focusing the Specimen (Fig.18)

1. Focus the specimen with 10X objective. To avoid the objective touching the specimen during focusing, you should raise the mechanical stage to let the specimen close to the objective at first, then slowly separate them to bring the specimen to focus.

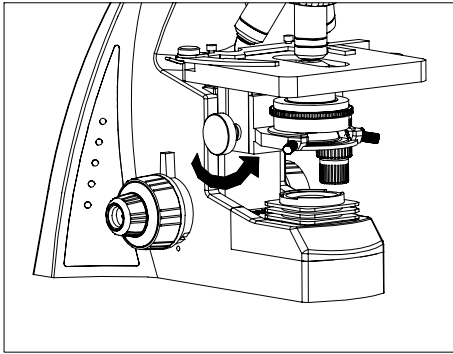

Fig.19

Turn the coarse focus knob ① conversely to lower the specimen and search images in the 10 \times ocular simultaneously, and then use the fine knob ② to focus. After that, you can replace with other magnification objectives safely, and focus without the risk of damaging the specimen.

- ★ To make the observation more convenient, you can use the locking set ③ to fix the stage in a vertical direction.

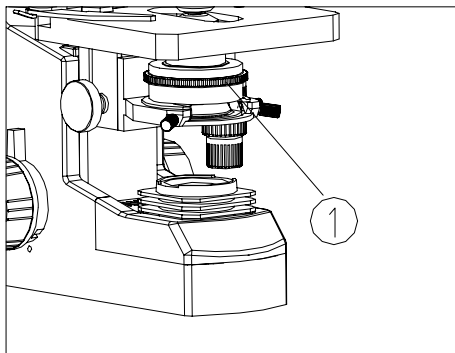

Fig.20

3.3.4 Condenser Adjustment (Fig.20)

Turn the condenser focus knob to move the condenser up and down. Raise the condenser when using the high magnification objective, and descend it when using the low magnification one.

- ★ The condenser and the objective are coaxial. It has been adjusted before leaving factory, so the user needn't to adjust them by self
- ★ The highest position of the condenser has been adjusted too. It also needn't any user's operation.

3.3.5 Aperture Iris Diaphragm Adjustment (Fig.20)

Turn the aperture iris diaphragm collar ① to adjust the aperture iris diaphragm.

- ★ The aperture iris diaphragm is designed for the adjustment of the numerical aperture, not for the brightness.

Generally, setting the aperture iris diaphragm to 70- 80% of the N.A. of the objective in use will provide an image with good contrast. If you want to observe the image of the aperture iris diaphragm, remove one eyepiece and look through the tube. You will see a dark circle encroaching on the bottom of the tube.

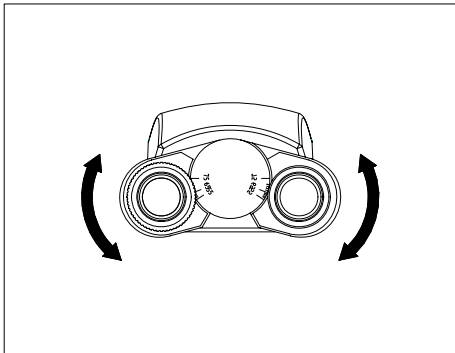

Fig.21

3.3.6 Adjusting the Interpupillary Distance (Fig.21)

The interpupillary distance range:

55mm~75mm。

While looking through the eyepieces, move both eyepieces until the left and right fields of view coincide completely.

3.3.7 Adjusting the Diopter (Fig.22)

1. Turn the eyepiece① to adjust the diopter while looking through it.

★ The diopter range of the eyepiece is ± 5 diopter. The number aligned to the line on the viewing head is the diopter in use.

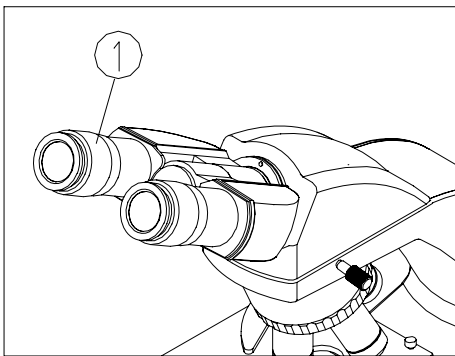

Fig.22

3.3.8 Adjusting the tension adjustment collar (Fig.23)

Turn the tension adjustment collar① with your fingers. When the collar is turned in the direction of the arrow, tension of the coarse adjustment knob② increases. Turning the collar in the opposite direction decreases the tension.

If the nosepiece descends on its own or if the specimen gets out of focus quickly even when it is brought into focus using the fine adjustment knob③, it means the tension of the coarse adjustment knob is too low. Turn the collar in the direction of the arrow to increase the tension

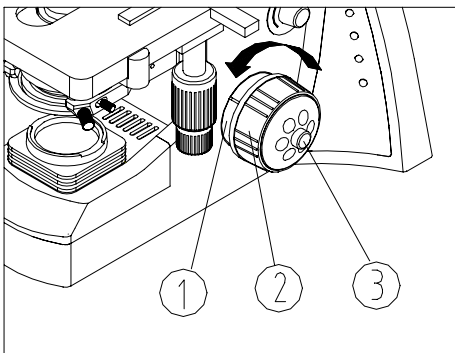

Fig.23

4. Technical Specifications

STM-2040BD

1)、 Main Specifications

Optical System	Infinite optical system
Viewing Head	Siedentopf Binocular Head, 30°Inclined, Interpupillary Distance 48-75 mm
Eyepiece	Wide Field Eyepiece WF 10X/18
Nosepiece	Quadruple Nosepiece
Objective	Infinite Semi-plan Objectives 4×, 10×, 40×, 100×
Focusing	Coaxial Coarse and Fine Adjustment, Moving Range 20mm, Fine Division 0.002mm
Condenser	Abbe Condenser, NA=1.25
Stage	Double Layers Mechanical Stage 140mm×140mm, Moving Range 75×50mm
Illumination	6V20W Halogen Lamp

2)、 Eyepiece and objectives

1. objective

Magnification	Numerical Aperture	Focal Length (mm)	Working Length (mm)	Objective
4×	0.10	45.3	17	dry
10×	0.25	17.96	6	dry
40×	0.65	4.5	0.37	dry
100×	1.25	1.81	0.13	oil

2. Eyepiece

Eyepiece	Magnification	Focal Length (mm)	Field of View (mm)
Wide field plan eyepiece	10×	25	φ22

5. Outfit**STM-2040BD**

Main Body	Main Standard	Optional
	Double Layers Mechanical Stage	Optional
	Condenser Holder	Optional
Viewing Head	Siedentopf Binocular Head	Optional
Condenser	Abbe Condenser, NA=1.25	Optional
Nosepiece	Quadruple	Optional
Illumination	6V20W Halogen Lamp	Optional
	Spare Bulb	Optional
Eyepiece	10×Wide Field Plan Eyepiece	Optional
Objective	Infinite Semi-Plan Objective 4×	Optional
	Infinite Semi-Plan Objective 10×	Optional
	Infinite Semi-Plan Objective 40×	Optional
	Infinite Semi-Plan Objective 100× (Oil)	Optional
Condenser	Bright Field Condenser with Adjustable Iris Diaphragm	Optional
Filter	Baby Blue, Green	Optional

6. Troubleshooting Guide**STM-2040BD****1. Optical System**

TROUBLE	CAUSE	SOLUTION
1. The edge of the field of view is dark or the brightness is not uniform	The nosepiece is not in the located position (objective and light path not coaxial)	Locate the nosepiece properly where it clicks
	The surface of the lamp becomes black	Change a new lamp bulb
	A lens (the objective, condenser, eyepiece or collector) is dirty.	Clean it thoroughly
2. Dirt or dust is visible in the field of view	Dirt/dust on the specimen	Replace with a clean specimen
	Dirt/dust on the eyepieces	Clean them
3. Visibility is poor Image is not sharp; Contrast is poor; Details are indistinct	Specimen is not covered	Add cover glass on it
	The thickness of the cover glass is not suitable	Use standard cover glass with thickness of 0.17mm
	Specimen is placed reversely	Turn it over
	Dry objective has oil on it. (especially for 40X objectives)	Wipe the oil
	A lens (the objective, condenser, eyepiece or collector) is dirty.	Clean it
	Immersion oil is not used with the 100x objective	Use specified oil
	Air bubbles existed in the immersion oil	Eliminate the bubble
	The aperture iris diaphragm is stopped down too far	Adjust the aperture iris diaphragm properly
	Dirt or dust on the eyepiece	Clean it
4. One side of image is blurred	Condenser is not properly centered	Center the condenser with the centering screw
	The nosepiece is not properly engaged	Engage the nosepiece properly
	The specimen is not clamped	Clamp it with stage clips
5. The image is yellowish	The blue filter is not used	Use the blue filter
6. The brightness is not enough	The aperture iris diaphragm is too small	Adjust it properly
	The condenser is too low	Adjust it properly
	A lens (the objective, condenser, eyepiece or collector) is dirty.	Clean it

2. Mechanical System

TROUBLE	CAUSE	SOLUTION
1. Field of view of one eye does not match that of the other	Interpupillary distance is incorrect	Adjust interpupillary distance
2. Observation is tiring	The diopter is not proper	Adjust the diopter properly
	The brightness of the illumination is not proper for eyes	Adjust the lamp voltage

3. Electrical System

TROUBLE	CAUSE	SOLUTION
1. The bulb cannot light	No power supply	Check the power cord connection
	The pin of the bulb doesn't insert properly	Insert the pin deeply
	The bulb broken	Replace with a new one
2. The bulb burns out suddenly	The bulb is not the specified one; The voltage is too high	Use the specified bulb; lower the voltage
3. the illumination is not bright enough	the voltage is too low	Raise the voltage
4. Image flicks	The bulb is about to burn out	Replace with a new one
	The bulb is not inserted deeply	Check its connection