

Biological Microscope

Model: STM-2036C

Instruction Manual



This manual is written for biological microscope STM-2036C. To ensure the safety, obtain optimum performance and to familiarize you fully with the use of this microscope, it is recommended strongly that you study this manual thoroughly before using the microscope and retain this manual in an easily accessible place near the work desk for future reference.

CONTENTS

Purpose	1
1. Parts Name	2
2. Specifications	3
3. Installation	4
4. Operation	5
5. Image Collection	5
6. Maintenance	6
7. Troubleshooting	7
8. Outfits	8

STM-2036C biological microscope is designed for college teaching, clinical verify. The microscope with original style, steady structure, convenient operation and clear image is suitable for observing various biological specimens, and mostly applied in college and hospital.



1. Pars Name

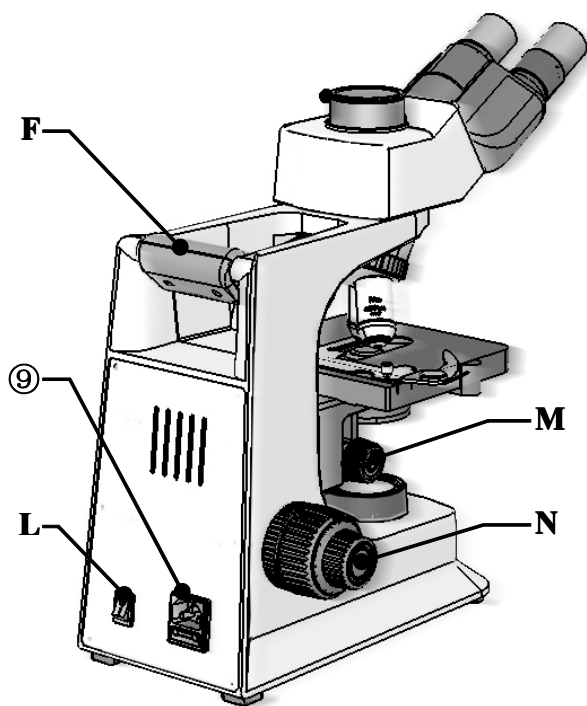
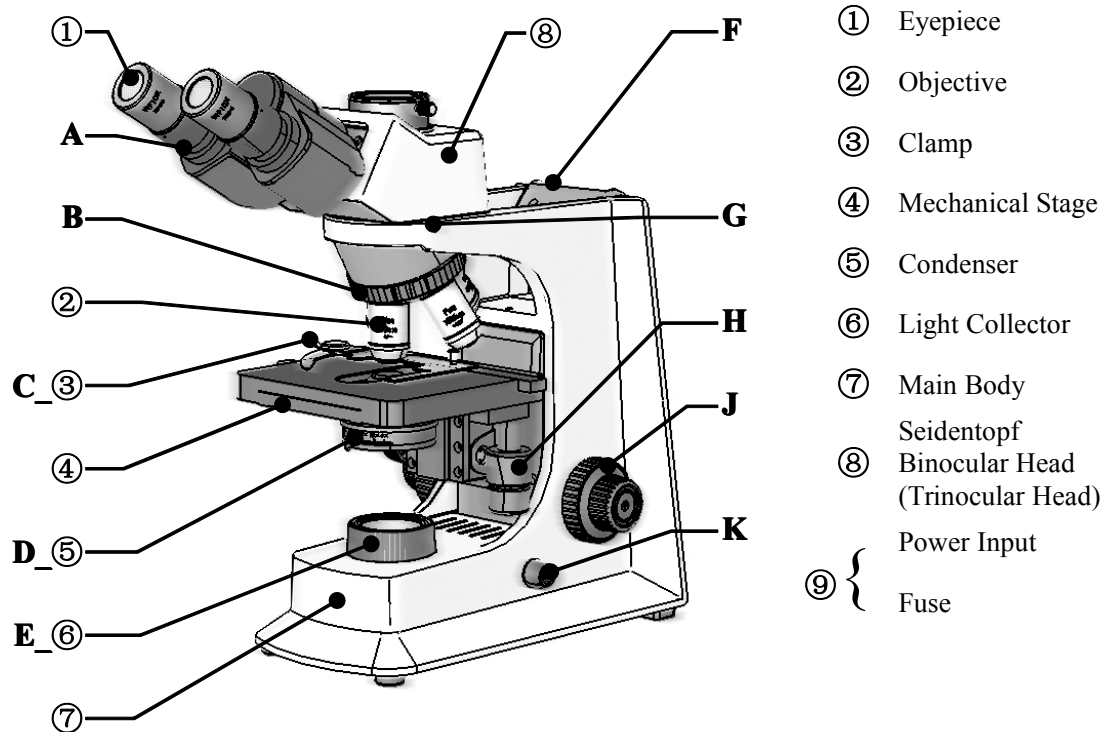

- A** Diopter Adjustment Ring
- B** Nosepiece
- C** Clamp Handle
- D** Handle of Iris Aperture Diaphragm
- E** Field Diaphragm Ring
- F** Body Handle
- G** Head Thumb Screw
- H** Mechanical Stage Moving Knob
- J** Right Coarse & Fine Focusing Knobs
- K** Potentiometer
- L** Power Switch
- M** Condenser Focusing Knob
- N** { Tension Adjustment Ring
 Left Coarse & Fine Focusing Knobs

2. Specifications

2.1 Total magnifications

Total Magnifications	Objective					
		4X	10X	20X (Optional)	40X	100X
Eyepiece	10X	40X	100X	200X	400X	1000X
	16X	64X	160X	320X	640X	1600X

2.2 Objectives

Objective	Numerical Aperture (N.A.)	Objective Field	Resolving Power	Working Distance
4X	0.10	5mm	2.8 μ m	6.73mm
10X	0.25	2mm	1.1 μ m	4.19mm
20X (S)	0.40	1mm	0.69 μ m	2.14mm
40X (S)	0.65	0.5mm	0.42 μ m	0.45mm
100X (Oil) (S)	1.25	0.2mm	0.22 μ m	0.12mm

2.3 The other specification

2.3.1 Mechanical tube length: 160mm

2.3.2 Conjugate distance: Infinity (Non- Infinity: 195mm)

2.3.3 Head: Seidentopf Binocular or Trinocular, Inclined 30° , Rotable 360° ,

Anti-fungal systems. Interpupillary Adjustable Distance Is 50-75mm,

Diopter adjustable range ± 5 .

2.3.4 Nosepiece: Quadplex nosepiece

2.3.5 Mechanical stage: Size 145mm \times 140mm

X-Y travel 76mm \times 52mm

2.3.6 Focusing systems: Coaxial Coarse and Fine Focusing Knobs, Coarse stroke 26mm,

Fine division 2 μ m, Condenser up-down range 22mm

2.3.7 Condenser: Abbe condenser, N.A. 1.25, Adjustable aperture, Aperture center can be adjustable.

2.3.8 Illumination: Non-spherical System

2.3.9 Filter: Built in blue filter

2.3.10 Electric components: Input voltage AC85-265V/LED AC170-270V, 50/60Hz

Output voltage DC1.2-6V/LED DC0.4-3.5V

6V/20W halogen lamp

Rotation potentiometer with power switch

Fuse 2A $\phi 5 \times 20$

3. Installation

Please clean the operation desk before installation. Put out the microscope of the carton and put it on the desk.

Make sure the supply voltage meets the instrument's requirement and the power switch is off.

Installation Instruction Fig.:

1. Turn the binocular (trinocular) head to working position;
2. Put out the dust cover of the eyepiece tube;
3. Insert into the eyepiece;
4. Install Abbe Condenser

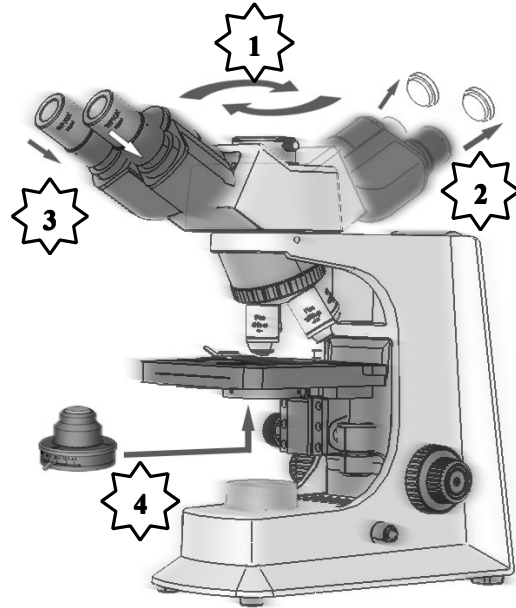

3.1 Eyepiece Tube:

Loose the Head Thumb Screw G, turn the tube to observing position, then tighten the Screw G.

3.2 Put out the eyepiece dust cover.

3.3 Eyepiece

Put out the eyepiece of the carton, and insert it into the tube. Please don't touch the lens of the eyepiece by hand.

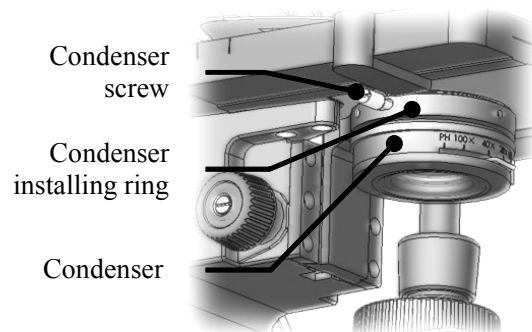

3.4 Condenser

Put out the condenser of the carton, then turn Condenser Focusing Knob M to lower condenser installing ring. Loose the condenser screw, then install the condenser, and make the condenser graduation face to the front, Tighten the condenser screw, and higher the condenser installing ring to top.

Please don't touch the lens by hand.

3.5 Power

Put in power, open Switch L, and turn Potentiometer J.

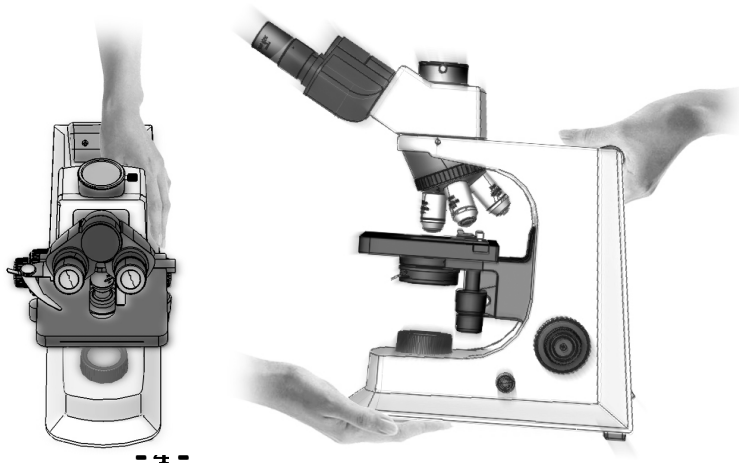

4. Operation

4.1 Bright field operation process instruction

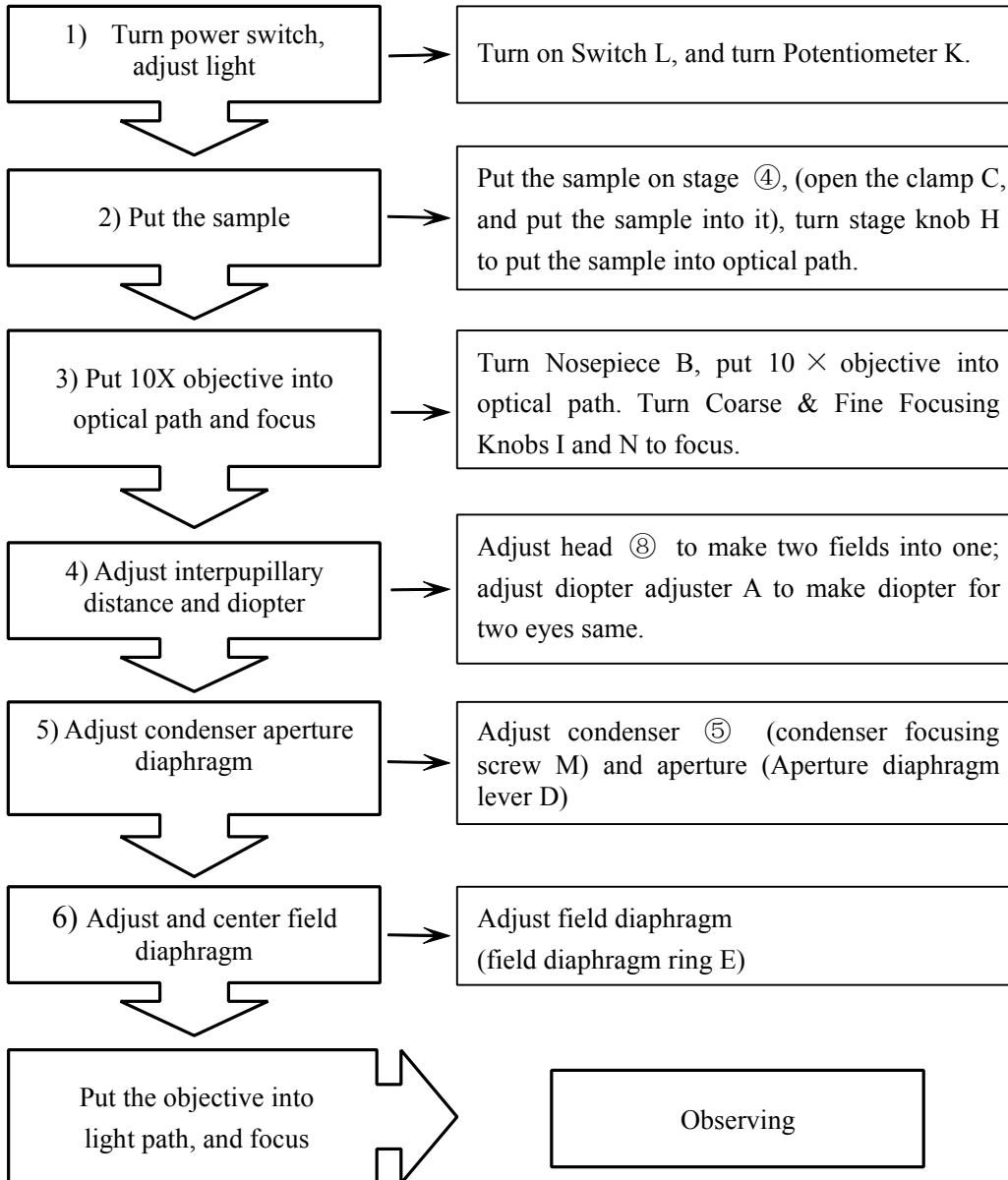

5. Image Collection

5.1 Installing

Connect the C-mount with CCD camera or connect camera with camera adaptor, then connect it with c-mount, finally put it into microscope.

5.2 Using

First get a clear image from eyepiece, then put out lever on the side of trinocular head, and collect image with camera. Clear image should be in screen. Adjust B14 fine focusing knobs to get it clear if image isn't clear.

6. Maintenance

6.1 Clean microscope

6.1.1 Don't touch the lens with hand, Dust on lens should be cleaned by soft brush or absorbent cotton or cleaned by absorbent cotton, lens paper with the mixture of alcohol and ether (proportion 1:4).

6.1.2 Alcohol and ether all are burnt early, please take them away from fire. Be careful for turn on and off power.

6.1.3 Don't clean painted metal and galvanizing metal with organic solvent such as alcohol, ether or the mixture of the both. Silicon cloth or soft cleaning preparation is suggested to clean it.

6.1.4 Plastic should be cleaned by soft cloth with clear water.

6.2 Environment of using and placing

6.2.1 Microscope should be used and placed in a cool, dry, non-dust, non-shake and non-corrosive gases environment.

6.2.2 Microscope should be used in environment of indoor temperature 0° - 40° C and maximum relative humidity 85%.

6.2.3 Removing equipment is suggested to be installed when microscope used in heavy humidity area to avoid fungus and mist damage instrument.

6.2.4 Please pay attention to prevent microscope from violent shake and vibration in application and in carrying. Don't drag it on the surface of worktable to avoid damage to microscope and worktable.

6.3 Replacement of bulb

6.3.1 Turn off power, and pull out plug.

6.3.2 Wait the bulb become cool.

▲ Please be sure that the bulb is cool, then follow by the next operations.

6.3.3 Lay aside the microscope reliably, unscrew the knurled thumb screw of the lamp housing cover on the underside of base.

6.3.4 Pull over the lamp housing cover.

6.3.5 Pull out the bulb should be replaced, hold a new bulb with silk cloth to avoid fingerprint and dust

affect bulb brightness and service life, and insert fully the contact pins into the bulb socket.

6.3.6 Close the lamp housing cover, and screw the knurled thumb screw.

▲After working for above 10 hours continuously, better cut off the microscope about 30 minutes.

6.4 Replacement of fuse

6.4.1 Cut off power of microscope, and pull out the plug.

6.4.2 Unscrew fuse cap in the back of base, take out old fuse.

6.4.3 Replace a new fuse, then screw the fuse cap.

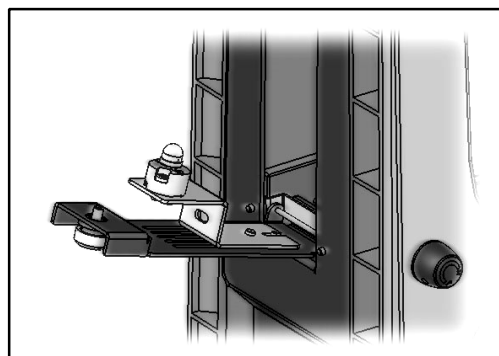

7. Trouble shooting

In the period of using this series microscope, if there is any trouble occurs, please referring to the following sheet listed some common troubleshooting resolve them.

Trouble	Causation	Remedy
Switch on but bulb dark	Plug is unreliable	Plug in again
	Bulb is broken	Change bulb
	Fuse is broken	Change fuse
Bulb is flickering or brightness is unsteady	Bulb is unstable	Insert it again
	Bulb is broken	Replacing bulb
Brightness of view field isn't enough or is Uneven	Bulb specification doesn't meet the requirement	Replacing bulb
	Brightness isn't adjusted correctly	Adjust rotation potentiometer
	Objective isn't in correct position	Make the objective in correct position
	The size of iris aperture is too small	Adjust the size of iris aperture
Brightness of view field isn't enough or is Uneven	Lens (objective, eyepiece, condenser, light collector) has dust	Clean it
	Position of condenser is too low	Higher condenser
Image isn't clear (contrast or definition isn't enough)	Cover glass of specimen doesn't meet the requirement	Use required thickness cover glass (0.17mm)
	Cover glass of specimen isn't in up direction	Place specimen correctly
	Surface of objective lens is dirty (especially it is easy for the front lens of 40X objective to dip in immersion oil)	Clean it
	Immersion oil isn't used for 100X objective (oil)	Use immersion oil
	Immersion oil doesn't meet the requirement	Use immersion oil supplied by us
	There is bubble in immersion oil	Clear the bubble way
	Size of iris aperture isn't proper	Adjust the size of iris aperture
	Position of condenser is too low	Readjust the position of condenser
One side of image is dark or image is moving as focusing	Objective isn't in correct position	Make the objective in correct position
	Specimen isn't placed correctly	Place specimen levelly on stage and clip it with clamp
Objective touches specimen as changing low times objective to high times objective	Cover glass of specimen isn't in up direction	Place specimen correctly
	Cover glass doesn't meet the requirement	Use required thickness cover glass (0.17mm)
Image observed by two eyes aren't in superposition entirely.	Interpupillary distance isn't adjusted correctly	Adjust interpupillary distance according to two eyes

Trouble	Causation	Remedy
It is easy for eyes to be tired during observing	Diopter isn't adjusted correctly	Readjust diopter

8. Outfits

Items	Specification	STM-2036C
Eyepiece	WF 10×-18 mm	
	WF 10×-20mm	Standard
	WF16×-13mm	Optional
	Reticule Eyepiece WF 10×-18 mm (Reticule 0.1mm)	Optional
	Reticule Eyepiece WF 10×-20mm (Reticule 0.1mm)	Optional
Achromatic Objective	4×	
	10×	
	20×	
	40× (S)	
	100×/1.25 (Oil) (S)	
Plan Objective	4×	
	10×	
	40×/0.65 (S)	
	100×/1.25 (Oil) (S)	
Infinity E-Plan Objectives	4×	Standard
	10×	Standard
	20×	Optional
	40× (S)	Standard
	100× (Oil) (S)	Standard
Seidentopf Binocular Head	Inclined 30°, Rotatable 360°, Interpupillary Distance: 50-75mm	
Seidentopf inocularHead (For Infinity System)	Inclined 30°, Rotatable 360°, Interpupillary Distance: 50-75mm	Standard
Trinocular Head	Inclined 30°, Rotatable 360°, Interpupillary Distance 50-75mm, Light Distribution: 20:80	
Trinocular Head (For Infinity System)	Inclined 30°, Rotatable 360°, Interpupillary Distance 50-75mm, Light Distribution: 20:80	Optional
Nosepiece	Quadplex	Standard
Mechanical Stage	Stage Size: 145X140mm Travel: 76mmX52mm Coaxial Coarse and Fine Focusing Knobs	Standard
Condenser	Abbe N.A. 1.25 (Iris Diaphragm)	Standard
Illumination	6V/20W Halogen Lamp	Standard
	LED Illumination Systems	Optional
Filter	Blue	Standard
	Green	Optional
	Yellow	Optional

Packing Size: 420mm × 275mm × 450mm
Gross Weight: 7.5 kgs Net Weight: 6.5 kgs

